

PRODUCT DATA SHEET

Marlo Kitchen Tap

Product Code: NICK14L



Product Name	NICK14L
Product Description	Marlo Kitchen Tap - Brushed Nickel
Product Transportation	
Barcode	5060500647940
Country of origin	CH
Commodity code	8481801190
Product Measurements	
Product Weight (KG)	1.5
Product Width (mm)	120
Product Height (mm)	385
Product Depth (mm)	282.8
Product Length (mm)	0
Primary Packed Measurements	
Packaged Weight	2
Packed Length	38.5
Packed Width	29
Packed Height	5.5
Packaging Weights	
Card (kg)	0.224
Paper (kg)	11
Wood (kg)	n/a
Plastic (kg)	0.004
Compliance DOP	HBD0C007 , HBD0C008

General Information	
Construction Material	Brass , Stainless Steel
Installation type	Deck Mounted
Colour / Finish	Brushed Nickel
Tap / Shower Attributes	
WRAS Approved	Yes
TMV Approved	No
Minimum Operating Pressure (bar)	0.2
Maximum Operating Pressure (bar)	5
Flexible Tails Included	Yes
Number of tap holes required	1
Handle Type	Lever
Swivel Spout	Yes
Inlet Connection	1/2" M10
Outlet Connection	N/a
Tap Hole Diameter (mm)	35
Tap Type description	Manual Mixer
Includes Waste	No
Valve / Cartridge Type	Quarter Turn Cartridge
Cartridge Spare code	T7507-08
Flow Rates	
0.2bar (l/min)	3.4
0.5bar (l/min)	5.6
1bar (l/min)	7.8
2bar (l/min)	10.8
3bar (l/min)	13.05

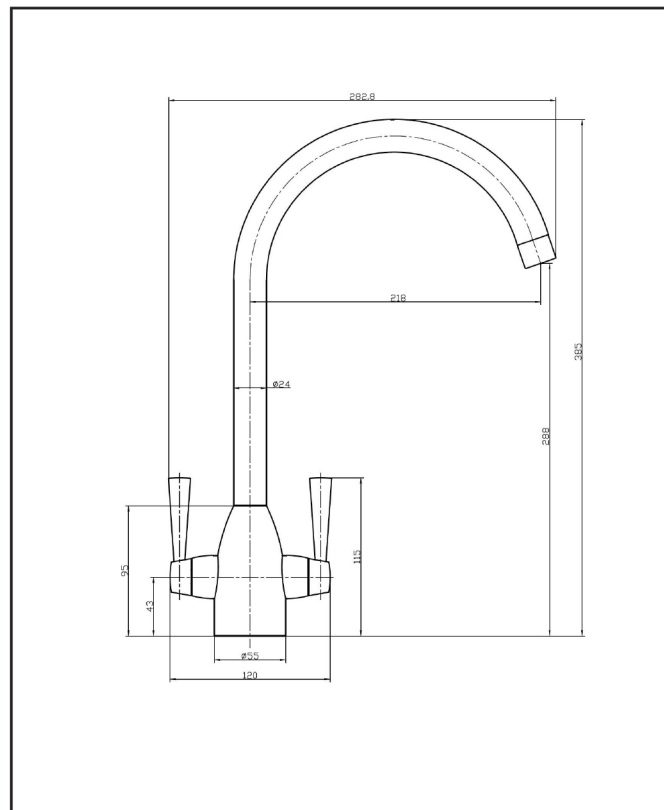

Dimensions
(measurements in mm)

CNM Online

T: 01977 663331 **E:** cnmservice@cnmonline.co.uk

Unit 2, North Point Business Park, Selby Road, Eggborough, North Yorkshire, DN14 0JT