

## OPERATION AND INSTALLATION

Wall mounted DHW cylinder

- » SHZ 30 S (GB)
- » SHZ 50 S (GB)
- » SHZ 100 S (GB)
- » SHZ 150 S (GB)

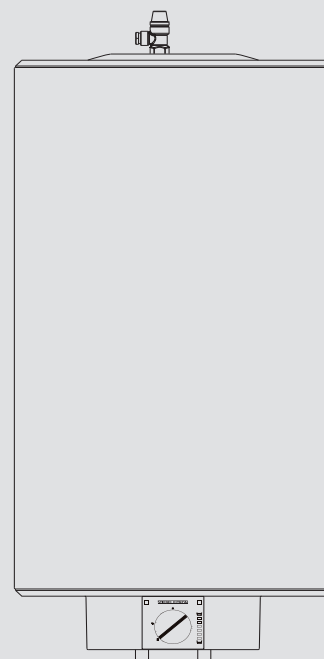

**STIEBEL ELTRON**

## SPECIAL INFORMATION

### OPERATION

<b>1. General information</b>	<b>3</b>
1.1 Safety instructions	3
1.2 Other symbols in this documentation	3
1.3 Units of measurement	3
<b>2. Safety</b>	<b>3</b>
2.1 Intended use	3
2.2 General safety instructions	3
2.3 Test symbols	4
<b>3. Appliance description</b>	<b>4</b>
3.1 Frost protection	4
<b>4. Settings</b>	<b>4</b>
<b>5. Cleaning, care and maintenance</b>	<b>5</b>
<b>6. Troubleshooting</b>	<b>5</b>

### INSTALLATION

<b>7. Safety</b>	<b>5</b>
7.1 General safety instructions	5
7.2 Instructions, standards and regulations	5
<b>8. Appliance description</b>	<b>5</b>
8.1 Standard delivery	5
8.2 Accessories	5
<b>9. Preparations</b>	<b>6</b>
9.1 Installation site	6
9.2 Wall mounting bracket	6
9.3 Preparing the power cable	6
<b>10. Installation</b>	<b>6</b>
10.1 Appliance installation	6
10.2 Water connection and safety assembly	6
10.3 Power connection	7
10.4 Completing the installation	7
<b>11. Commissioning</b>	<b>7</b>
11.1 Commissioning	7
11.2 Recommissioning	8
<b>12. Settings</b>	<b>8</b>
<b>13. Shutting down</b>	<b>8</b>
<b>14. Troubleshooting</b>	<b>8</b>
<b>15. Maintenance</b>	<b>9</b>
15.1 Checking the safety assembly	9
15.2 Draining the appliance	9
15.3 Replacing the protective anode	9
15.4 Descaling	9
15.5 Anti-corrosion protection	9
<b>16. Specification</b>	<b>10</b>
16.1 Dimensions and connections	10
16.2 Minimum clearances	11
16.3 Controller-limiter combination immersion depths	11
16.4 Wiring diagrams and terminals	11
16.5 Hydraulic diagram	13
16.6 Heat-up diagrams	13

16.7 Fault conditions	13
16.8 Details on energy consumption	14
16.9 Data table	14

### GUARANTEE

### ENVIRONMENT AND RECYCLING

## SPECIAL INFORMATION

- The appliance may be used by children aged 8 and older and persons with reduced physical, sensory or mental capabilities or a lack of experience and know-how, provided that they are supervised or they have been instructed on how to use the appliance safely and have understood the resulting risks. Children must never play with the appliance. Children must never clean the appliance or perform user maintenance unless they are supervised.
- The connection to the power supply is only permissible as a permanent connection in conjunction with the removable cable grommet. Ensure the appliance can be separated from the power supply by an isolator that disconnects all poles with at least 3 mm contact separation.
- Observe the maximum permissible pressure (see chapter Installation / Specification / Data table).
- The appliance is pressurised. During the heat-up process, expansion water will drip from the safety valve.
- Regularly activate the safety valve to prevent it from becoming blocked, e.g. by limescale deposits.
- Drain the appliance as described in chapter „Installation / Maintenance / Draining the appliance“.
- Install a type-tested safety valve in the cold water supply line. Please note that, depending on the static pressure, you may also need a pressure reducing valve.

- Size the drain so that water can drain off unimpeded when the safety valve is fully opened.
- Fit the discharge pipe of the safety valve with a constant downward slope and in a room free from the risk of frost.
- The safety valve discharge aperture must remain open to atmosphere.

# OPERATION

## 1. General information

The chapters "Special Information" and "Operation" are intended for both the user and qualified contractors.

The chapter "Installation" is intended for qualified contractors.



**Note**  
 Read these instructions carefully before using the appliance and retain them for future reference. Pass on the instructions to a new user if required.

### 1.1 Safety instructions

#### 1.1.1 Structure of safety instructions



**KEYWORD Type of risk**  
 Here, possible consequences are listed that may result from failure to observe the safety instructions.  
 ► Steps to prevent the risk are listed.

#### 1.1.2 Symbols, type of risk

Symbol	Type of risk
	Injury
	Electrocution
	Burns (burns, scalding)

#### 1.1.3 Keywords

KEYWORD	Meaning
DANGER	Failure to observe this information will result in serious injury or death.
WARNING	Failure to observe this information may result in serious injury or death.
CAUTION	Failure to observe this information may result in non-serious or minor injury.

## 1.2 Other symbols in this documentation



**Note**  
 General information is identified by the symbol shown on the left.  
 ► Read these texts carefully.

Symbol	Meaning
	Material losses (appliance, consequential and environmental losses)
	Appliance disposal

► This symbol indicates that you have to do something. The action you need to take is described step by step.

## 1.3 Units of measurement



**Note**  
 All measurements are given in mm unless stated otherwise.

## 2. Safety

### 2.1 Intended use

The appliance is intended for heating domestic hot water and can supply one or more draw-off points.

This appliance is designed for domestic use. It can be used safely by untrained persons. The appliance can also be used in a non-domestic environment, e.g. in a small business, as long as it is used in the same way.

Any other use beyond that described shall be deemed inappropriate. Observation of these instructions and of instructions for any accessories used is also part of the correct use of this appliance.

### 2.2 General safety instructions



**WARNING Burns**  
 During operation, the tap and safety assembly can reach temperatures in excess of 60 °C.  
 There is a risk of scalding at outlet temperatures in excess of 43 °C.



**WARNING Injury**  
 The appliance may be used by children aged 8 and up and persons with reduced physical, sensory or mental capabilities or a lack of experience provided that they are supervised or they have been instructed on how to use the appliance safely and have understood the resulting risks. Children must never play with the appliance. Children must never clean the appliance or perform user maintenance unless they are supervised.

# Appliance description



**Material losses**

Protect the water lines and the safety assembly against frost.



**Note**

The appliance is under pressure. During the heat-up process, expansion water will drip from the outlet side of the safety valve and / or of the T&P valve. If water continues to drip when heating is completed, please inform your qualified contractor.

### 2.3 Test symbols

See type plate on the appliance.

## 3. Appliance description

The appliance heats domestic hot water electrically subject to the connected heating output or with rapid heat-up. You can adjust the temperature using the temperature selector. Subject to the power supply, the water is heated automatically to the required temperature. The currently available heat content is displayed.

The internal steel cylinder is coated with special directly applied enamel and is equipped with a protective anode. The anode protects the internal cylinder from corrosion.

### Dual circuit operation

During off-peak tariff periods (power supply utilities' enable times), the appliance automatically heats up the water content subject to the connected heating output and temperature setting. In addition, you can start the booster heater during peak tariff periods.

### Single circuit operation

In this operating mode, the appliance heats up the water automatically subject to the connected heating output and temperature setting.

### Manual rapid heat-up operation

The appliance heats the water if the rapid heat-up button is pressed. Once the selected temperature has been reached, the appliance switches off and does not restart.

### 3.1 Frost protection

The appliance is also protected against frost on the temperature setting "cold" subject to it being switched 'live'. The appliance switches on in good time and heats the water. The water supply lines and the safety assembly are not protected against frost by the appliance. You can use the appliance in single circuit, dual circuit or manual rapid heat-up operation.

## 4. Settings

The temperature can be freely adjusted.

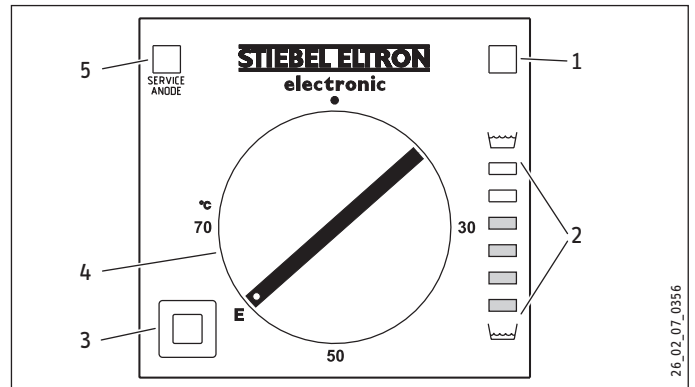

- 1 ON/OFF indicator
- 2 Heat content indicator
- 3 Rapid heat-up key
- 4 Temperature selector
- 5 SERVICE ANODE indicator
- Cold
- E Recommended energy saving position, low scaling, 60 °C
- 70 °C Maximum temperature setting

Depending upon the system, the actual temperatures may vary from the set value.



**Material losses**

▶ Notify your qualified contractor if the SERVICE ANODE indicator illuminates.

### Heat content indicator

The currently available mixed water volume is displayed at 40 °C with a cold water temperature of 15 °C and a temperature setting of 65 °C. The number of lights indicates the minimum available mixed water volume at 40 °C.

This enables you to match the temperature setting to your draw-off pattern to ensure optimum efficiency and save energy. We recommend you set the temperature initially to 65 °C. You can lower the set temperature if more than one indicator illuminates when your maximum draw-off volume is reached.

SHZ 30 S (GB)		10	20	30	40	50	60
SHZ 50 S (GB)		13	30	45	65	80	100
SHZ 100 S (GB)		25	60	90	130	160	200
SHZ 150 S (GB)		40	90	135	190	240	295

# OPERATION

## Cleaning, care and maintenance

### ON/OFF indicator

The ON/OFF indicator illuminates in single circuit and manual rapid heat-up operation while the water is heated, in dual circuit operation, it only illuminates during rapid heat-up.

### Dual circuit operation with rapid heat-up

You can switch on rapid heat-up with the corresponding key. A remote control can also be installed for this purpose. The rapid heat-up function stops and will not restart when the selected temperature has been reached.

### Manual rapid heat-up operation

You have to start the appliance with the rapid heat-up key. Once the selected temperature has been reached, the appliance switches off and does not restart.

## 5. Cleaning, care and maintenance

- ▶ Never use abrasive or corrosive cleaning agents. A damp cloth is sufficient for cleaning the appliance.
- ▶ Check the taps/valves regularly. You can remove limescale deposits at the spouts using commercially available descaling agents.
- ▶ Have the electrical safety of the appliance and the function of the safety assembly regularly checked by a qualified contractor.
- ▶ The protective anode must be replaced by the qualified contractor as soon as the SERVICE ANODE indicator illuminates (see chapter "Maintenance / Replacing the protective anode").

## 6. Troubleshooting

Fault	Cause	Remedy
The water does not heat up.	There is no power.	Check the fuses/MCBs in your fuse box.
The flow rate is low.	The aerator in the tap or shower head is scaled up or contaminated.	Clean and/or descale the aerator or shower head.
SERVICE ANODE indicator illuminates.	Replace the protective anode.	Notify your qualified contractor.

If you cannot remedy the fault, notify your qualified contractor. To facilitate and speed up your enquiry, please provide the serial number from the type plate (000000-0000-00000):

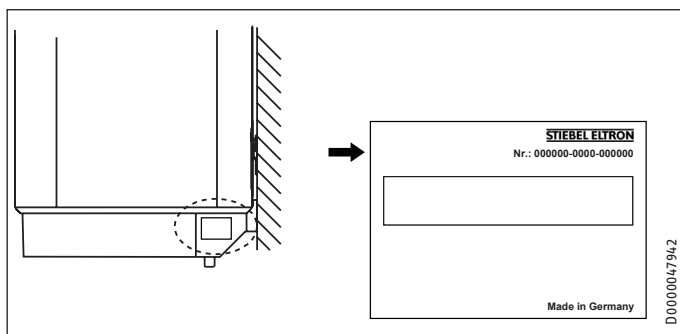

# INSTALLATION

## 7. Safety

Only a qualified contractor should carry out installation, commissioning, maintenance and repair of the appliance.

### 7.1 General safety instructions

We guarantee trouble-free function and operational reliability only if the original accessories and spare parts intended for the appliance are used.

### 7.2 Instructions, standards and regulations



#### Note

Observe all applicable national and regional regulations and instructions.

## 8. Appliance description

### 8.1 Standard delivery

Delivered with the appliance:

- Mounting bracket (2 pce for appliances with a 150 l nominal capacity)
- 5 mm spacer (2 pce for above, 2 pce for below)
- Installation template
- Safety assembly
- Expansion vessel, 8 litre
- Bracket
- Tundish

### 8.2 Accessories

Depending on the static pressure, various safety assemblies and pressure reducing valves are available. These type-tested safety assemblies protect the appliance against unacceptable excess pressure.

Pressure-tested taps are available as accessories.

# INSTALLATION

## Preparations

### 9. Preparations

#### 9.1 Installation site

The appliance is exclusively designed for installation on a solid wall. Ensure the wall offers adequate load bearing capacity.

Always install the appliance vertically in a room free from the risk of frost and near the draw-off point.

#### 9.2 Wall mounting bracket

- ▶ You can use the installation template to transfer the dimensions to the wall.
- ▶ Drill the holes and secure the wall mounting bracket with screws and rawl plugs. Select fixing materials in accordance with the wall construction/condition.

You can compensate for unevenness in the wall with the spacers provided.

2 mounting brackets are required for appliances with 150 l nominal capacity.

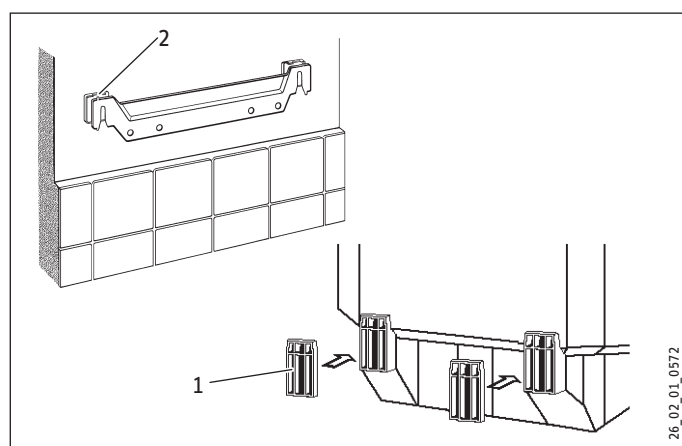

- 1 Lower spacer
- 2 Upper spacer

#### 9.3 Preparing the power cable

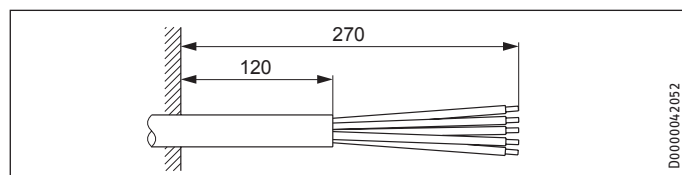

### 10. Installation

#### 10.1 Appliance installation

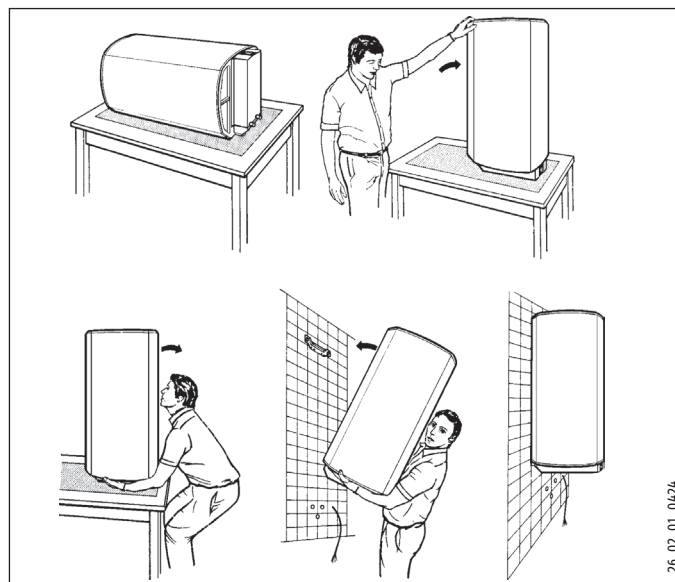

#### 10.2 Water connection and safety assembly



##### Material losses

Carry out all water connection and installation work in accordance with regulations.

##### Cold water line

Galvanised steel, stainless steel, copper and plastic are approved materials.

A safety valve is required.

##### DHW line

Stainless steel, copper and plastic pipework are approved materials.



##### Material losses

When using plastic pipework, observe chapter "Specification / Fault conditions".

The temperature setting can be limited by the qualified contractor. (see chapter "Settings / Limiting the temperature selection").

- ▶ Connect the hydraulic connections with flat gaskets.

Operate the appliance only with pressure-tested taps.

- ▶ Fit the safety assembly in the cold water supply line. Be sure to choose the appropriate safety assembly, according to the relevant static pressure.
- ▶ Observe the information in the installation instructions of the safety assembly.

# INSTALLATION

## Commissioning

See chapter "Specification / Hydraulic diagram" for the general arrangement in schematic form. You can fit the safety assembly in various positions to suit the space available but it must be placed in the same order as shown. The safety assembly provided in the pack is fitted to the cold water supply with the exception of the T&P valve which is fitted at the top of the DHW cylinder. DHW cylinder relief valve connections should not be used for other purposes. No valve should be fitted between the expansion valve and the DHW cylinder.

- ▶ To obtain a balanced water pressure in the cold water and DHW lines, position the cold water outlet directly on the outlet side of the pressure reducing valve.
- ▶ The expansion valve should not respond under normal operating conditions as the expansion vessel will accommodate the water as it expands during the heating process.
- ▶ Run the expansion valve outlet and that of the T&P valve to a drain via a tundish. The purpose of the tundish is to let water be seen should these valves respond. The outlet pipe should not exceed 9 metres in length without forming an air break, i.e. tundish. The pipe must fall continuously throughout its length with no additional 90° bends. It must be heat resistant and discharge to a safe visible position away from any electrical devices. The pipe diameter must not be smaller than the valve outlet. The two discharge pipes can be joined together at the point of discharge into a single tundish if required.

### 10.3 Power connection



#### WARNING Electrocutation

Carry out all electrical connection and installation work in accordance with relevant regulations.



#### WARNING Electrocutation

The connection to the power supply is only permissible as a permanent connection in conjunction with the removable cable grommet. The appliance must be able to be separated from the power supply by an isolator that disconnects all poles with at least 3 mm contact separation.



#### Material losses

Install a residual current device (RCD).



#### Material losses

Observe the type plate. The specified voltage must match the mains voltage.



#### Material losses

Ensure that the appliance is earthed.

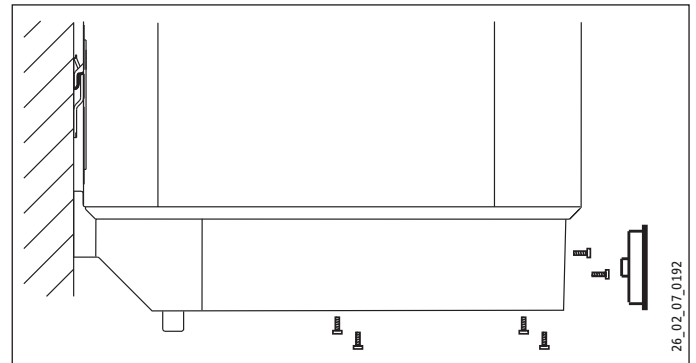

- ▶ Pull off the temperature selector.
- ▶ Undo the screws.
- ▶ Remove the bottom cap.
- ▶ Pull out the cable grommet at the base while pressing the snap-in tabs.
- ▶ Push the cable grommet over the connecting cable and snap the cable grommet back in place.
- ▶ Connect the power cable to the mains terminal (see chapter "Specification / Wiring diagrams and connections").
- ▶ Tick the selected connected load and voltage on the type plate with a ballpoint pen.

### 10.4 Completing the installation

- ▶ Replace the bottom cap.
- ▶ Insert the screws.
- ▶ Push on the temperature selector.
- ▶ Connect the safety assembly with the appliance by securing the pipes to the appliance with screws.

## 11. Commissioning

### 11.1 Commissioning

- ▶ Open a downstream draw-off point until the appliance has filled up and the pipes are free of air.
- ▶ Observe the maximum permissible flow rate with a fully opened tap (see chapter "Specification / Data table").
- ▶ If necessary reduce the flow rate at the butterfly valve of the safety assembly. Install the discharge pipe of the safety assembly with a constant slope. Observe the information in the installation instructions of the safety assembly.
- ▶ Turn the temperature selector to maximum.
- ▶ Switch the mains power ON.
- ▶ Check the function of the appliance. Ensure that the thermostat switches off.
- ▶ Check the function of the safety assembly.
- ▶ Check the function of the safety assembly.

# INSTALLATION

## Settings

### 11.1.1 Appliance handover

- ▶ Explain to users how the appliance and the safety assembly work and familiarise them with their operation.
- ▶ Make the user aware of potential dangers, especially the risk of scalding.
- ▶ Hand over these instructions.

### 11.2 Recommissioning

See chapter "Commissioning".

## 12. Settings

### Limiting the temperature selection

You can adjust the temperature selection limitation beneath the temperature selector.

- ▶ Set the temperature selector to "cold" and isolate the appliance from the power supply.
- ▶ Remove the temperature selector.

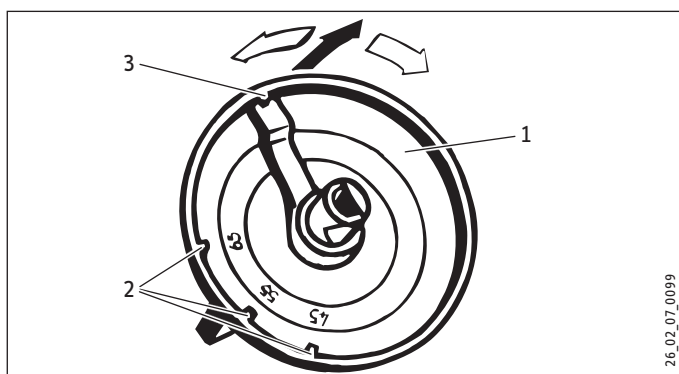

- 1 Temperature selector
  - 2 Temperature limit set to 45 °C, 55 °C, 65 °C.
  - 3 Factory setting 85 °C
- ▶ Adjust the temperature selection limit.
  - ▶ Replace the bottom cap.

## 13. Shutting down

- ▶ Disconnect the appliance from the mains at the MCB/fuse in the fuse box.
- ▶ Drain the appliance. See chapter "Maintenance / Draining the appliance".

## 14. Troubleshooting



### Note

The high limit safety cut-out can respond at temperatures below -15 °C. The appliance may be subjected to these temperatures during storage or transport.

Fault	Cause	Remedy
The water does not heat up.	The high limit safety cut-out has responded because the controller is faulty.	Remedy the cause of the fault. Replace the controller-limiter combination.
	The high limit safety cut-out has responded because the temperature has fallen below -15 °C.	Press the reset button (see diagram).
	The rapid heat-up does not switch on.	Check the button and lever.
	The flanged immersion heater is faulty.	Replace the flanged immersion heater.
The selected outlet temperature is not reached during manual rapid heat-up operation when the draw-off valve is fully opened.	More water flows through the appliance than the heating element can heat up.	Reduce the flow rate at the DHW valve.
The safety valve drips when heating is switched off.	The valve seat is contaminated.	Clean the valve seat.

### High limit safety cut-out reset button

The reset button is located behind the temperature selector.

- ▶ Pull off the temperature selector.

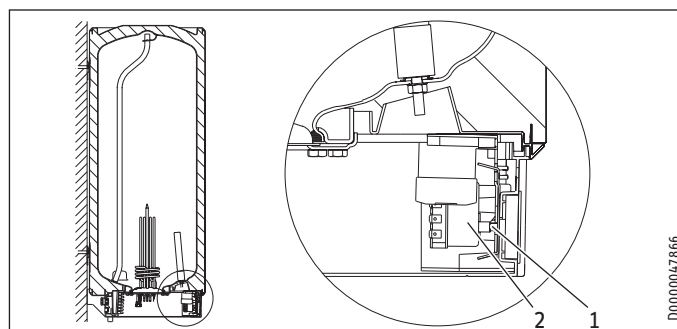

- 1 Reset key, high limit safety cut-out
- 2 Thermostat/limiter combination



### 15. Maintenance



**WARNING Electrocutation**  
Before any work on the appliance, disconnect all poles of the appliance from the power supply.

For some maintenance work you must remove the bottom cap.

If you also need to drain the appliance, observe chapter "Draining the appliance".

#### 15.1 Checking the safety assembly

- ▶ Regularly check the safety assembly.

#### 15.2 Draining the appliance



**WARNING Burns**  
Hot water may escape during the draining process.

If the cylinder needs to be drained for maintenance or to protect the whole installation when there is a risk of frost, proceed as follows:

- ▶ Close the shut-off valve in the cold water line.
- ▶ Open the hot water taps on all draw-off points.

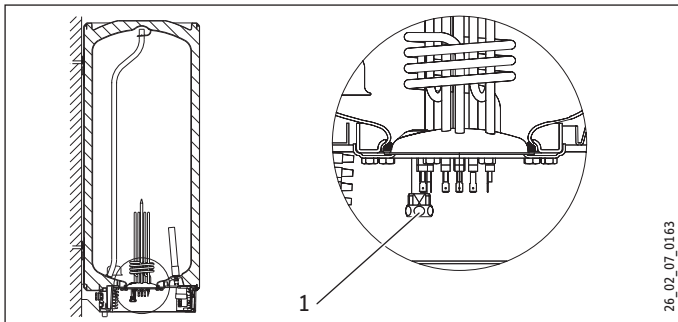

1 Drain valve cap G 1/2

- ▶ Undo the cap of the drain valve connection.

#### 15.3 Replacing the protective anode

- ▶ When replacing the anode, take great care not to fit the pressure switch too tightly.

Observe spanner size 13 of the anode and the maximum transition resistance of  $0.1 \Omega$  between the protective anode and the cylinder connection.

#### 15.4 Descaling

- ▶ Only descale the flange after disassembly and never treat the cylinder surface and protective anode with descaling agents.

#### 15.5 Anti-corrosion protection

Ensure when carrying out service work that the anti-corrosion protection on the insulating plate is not damaged or removed. Reinsert the anti-corrosion protection correctly after replacement.

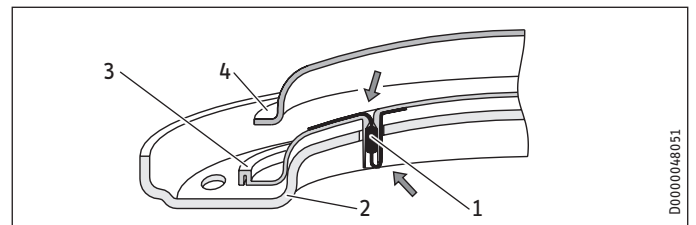

1 Corrosion resistor (390  $\Omega$ )

2 Pressure plate

3 Insulating plate

4 Copper flanged immersion heater

## 16. Specification

### 16.1 Dimensions and connections

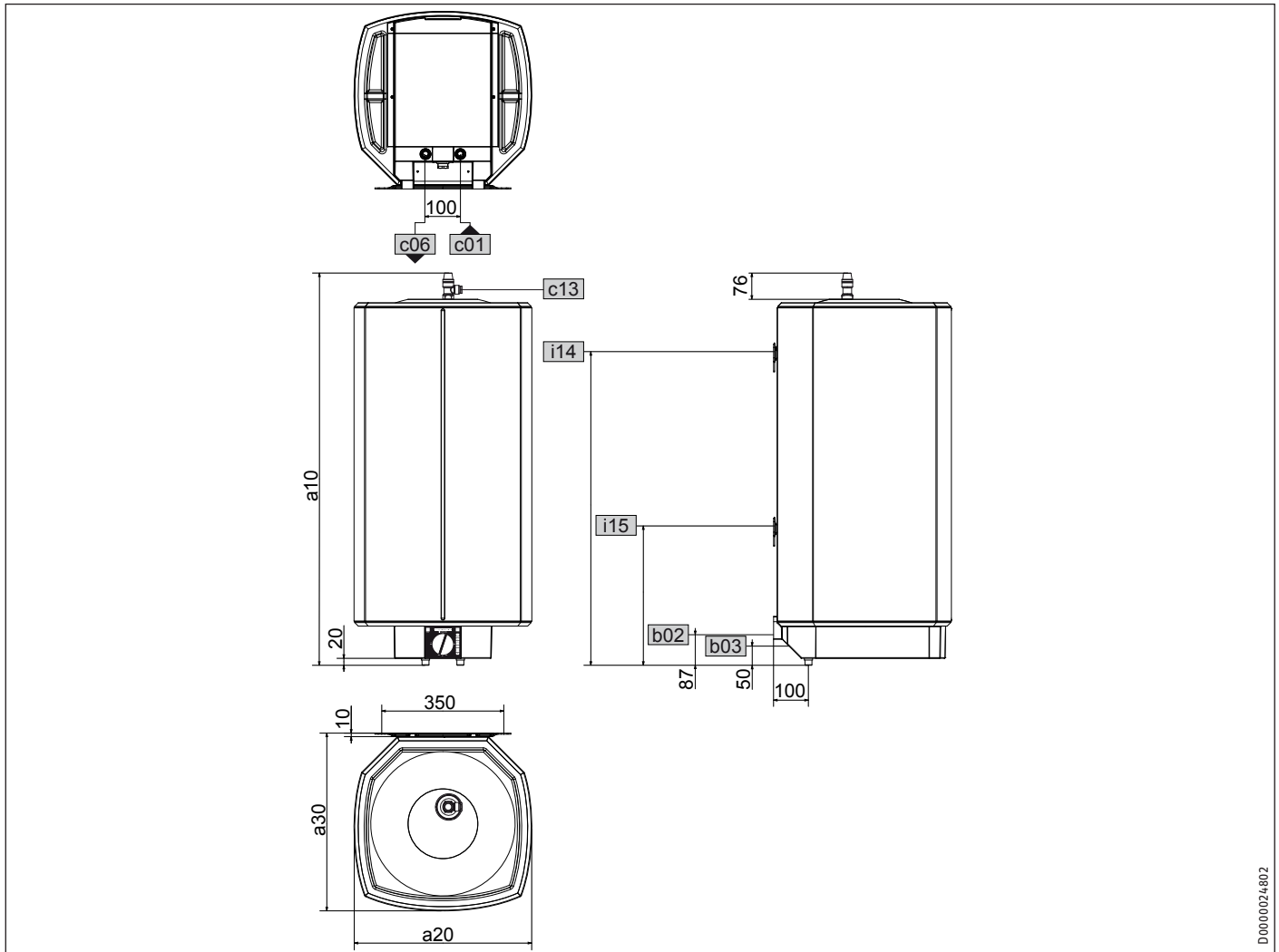

D0000024802

				SHZ 30 S (GB)	SHZ 50 S (GB)	SHZ 100 S (GB)	SHZ 150 S (GB)
a10	Appliance	Height	mm	846	816	1126	1521
a20	Appliance	Width	mm	410	510	510	510
a30	Appliance	Depth	mm	420	510	510	510
b02	Cable entry I			PG 21	PG 21	PG 21	PG 21
b03	Cable entry II			PG 11	PG 11	PG 11	PG 11
c01	Cold water inlet	Male thread		G 1/2 A	G 1/2 A	G 1/2 A	G 1/2 A
c06	DHW outlet	Male thread		G 1/2 A	G 1/2 A	G 1/2 A	G 1/2 A
c13	T&P valve						
i14	Wall mounting bracket I	Height	mm	700	600	900	1100
		Max. Ø fixing screw	mm	12	12	12	12
i15	Wall mounting bracket II	Height	mm				300
		Max. Ø fixing screw	mm				12

# INSTALLATION Specification

## 16.2 Minimum clearances

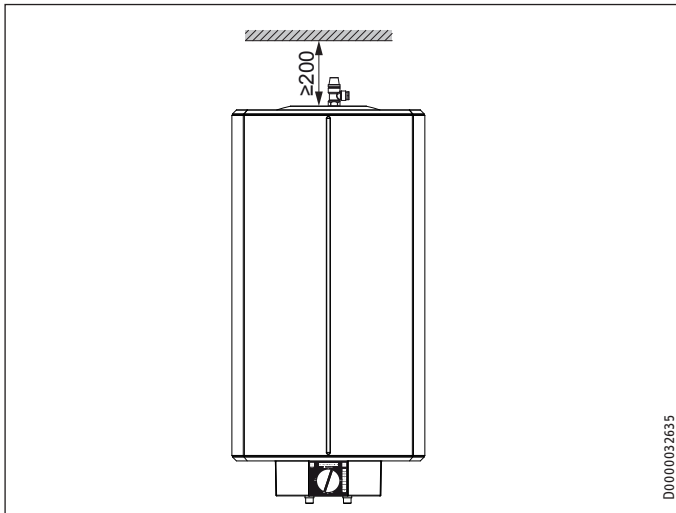

## 16.3 Controller-limiter combination immersion depths

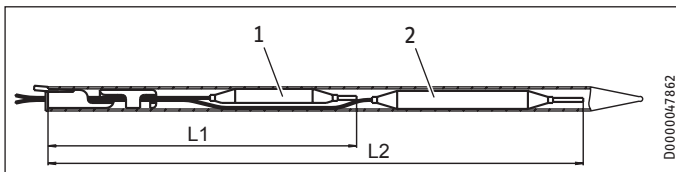

- 1 Limiter sensor
- 2 Controller sensor

			SHZ 30 S (GB)	SHZ 50 S (GB)	SHZ 100 S (GB)	SHZ 150 S (GB)
L1	Immersion depth	mm	260	260	240	260
L2	Immersion depth	mm	380	380	350	380

## 16.4 Wiring diagrams and terminals

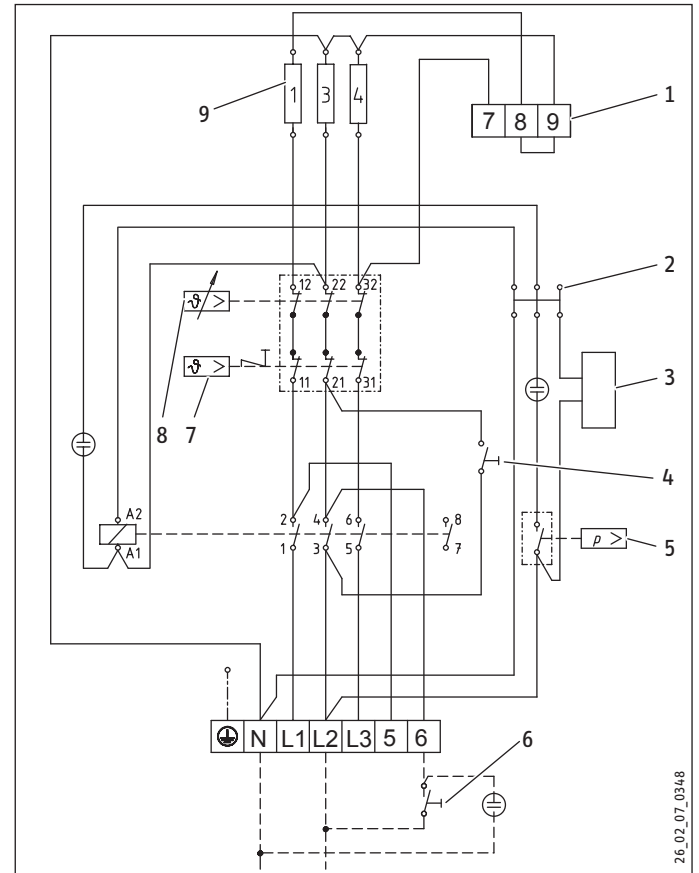

- 1 Terminal for output changeover
- 2 Plug-in distributor for N conductor
- 3 Heat content indicator
- 4 Rapid heat-up key
- 5 Pressure switch for signal anode
- 6 Remote control for rapid heat-up
- 7 High limit safety cut-out
- 8 Temperature controller
- 9 Heating element

# INSTALLATION Specification

## 16.4.1 Connection versions

### Dual circuit operation with single meter capture

1/3 kW 7 8 9 1/N/PE ~ 230 V

2/4 kW 7 8 9 1/N/PE ~ 230 V

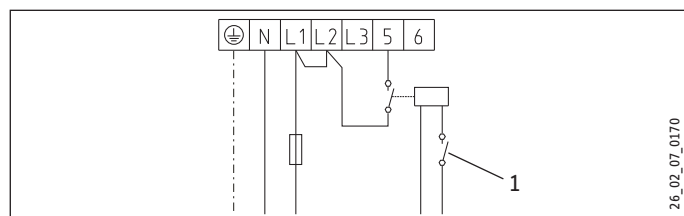

1 Power-OFF contact

### Dual circuit operation with dual meter capture

1/3 kW 7 8 9 1/N/PE ~ 230 V

2/4 kW 7 8 9 1/N/PE ~ 230 V

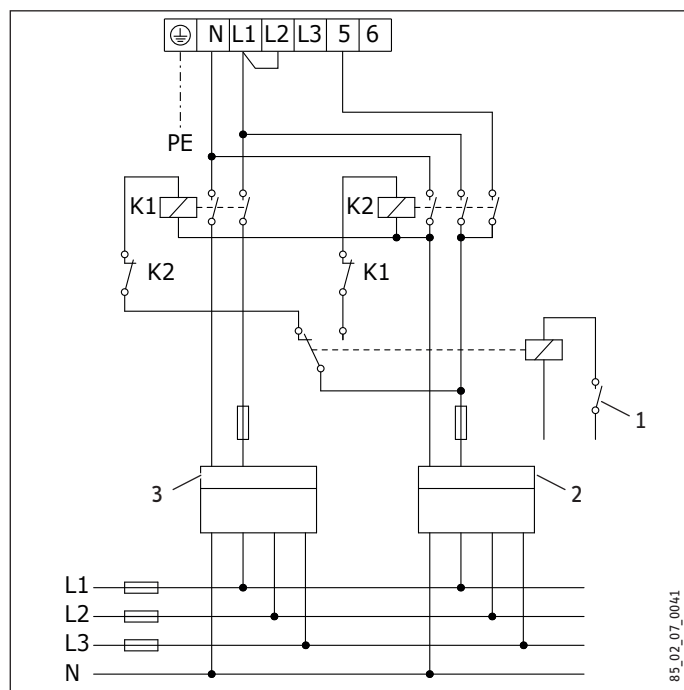

K1 Contactor 1

K2 Contactor 2

1 Power-OFF contact

2 Off-peak tariff meter

3 Peak tariff meter

### Single circuit operation

2 kW 7 8 9 1/N/PE ~ 230 V

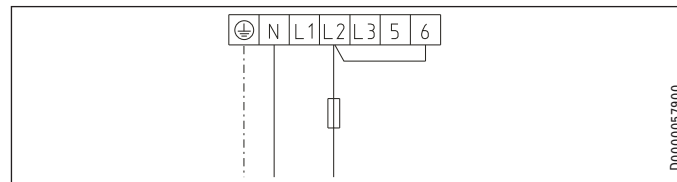

3 kW 7 8 9 1/N/PE ~ 230 V

4 kW 7 8 9 1/N/PE ~ 230 V

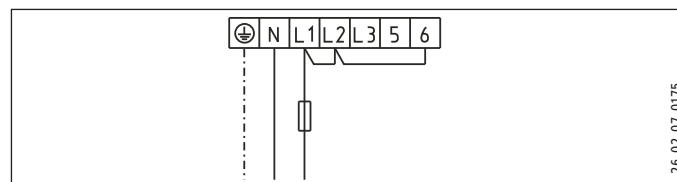

### Manual rapid heat-up operation

2 kW 7 8 9 1/N/PE ~ 230 V

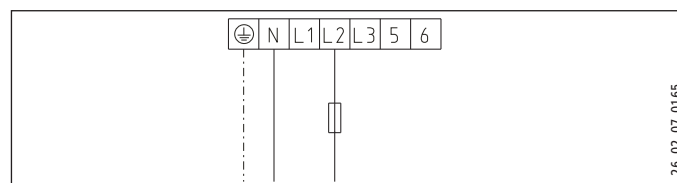

3 kW 7 8 9 1/N/PE ~ 230 V

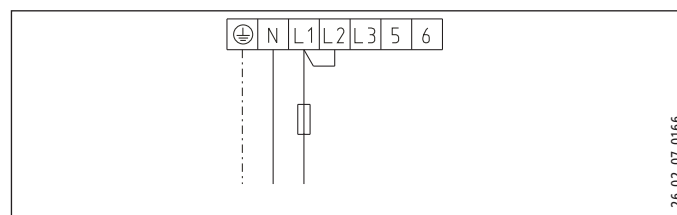

4 kW 7 8 9 1/N/PE ~ 230 V

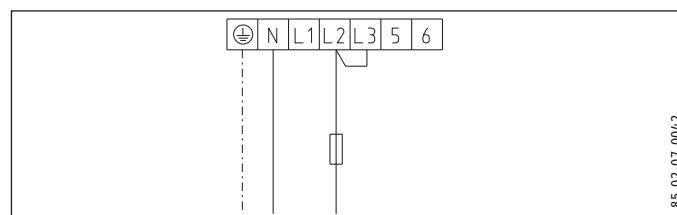

# INSTALLATION Specification

## 16.5 Hydraulic diagram

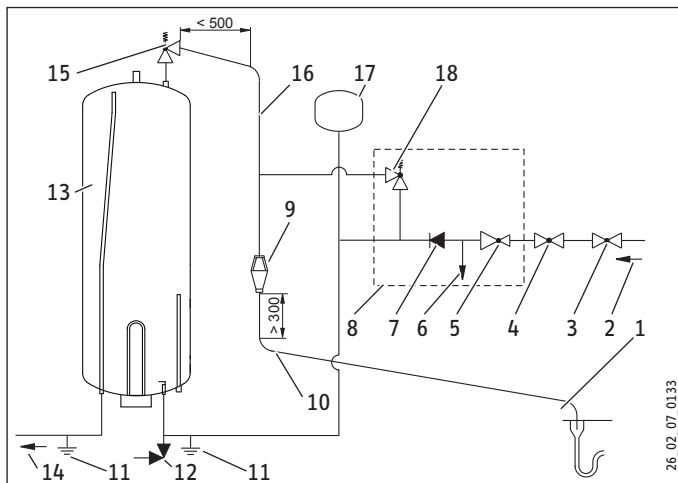

- 1 Discharge below fixed grate
- 2 Cold water supply
- 3 Shut-off valve
- 4 Line strainer
- 5 Pressure reducing valve
- 6 Balanced pressure; cold water outlet
- 7 Non-return valve
- 8 Safety assembly
- 9 Tundish
- 10 Metal discharge pipe (D2) from tundish, with continuous fall
- 11 Equipotential bond
- 12 Drain valve
- 13 Cylinder
- 14 DHW outlet
- 15 T&P valve
- 16 Metal discharge pipe (D1) from T&P valve to tundish
- 17 Expansion vessel
- 18 Expansion valve

Minimum size of discharge pipe D1	mm			15
Minimum size of discharge pipe D2 from tundish	mm	22	28	35
Maximum permissible pressure drop, expressed as a length of straight pipe (i.e. no elbows or bends)	m	9	18	27
Pressure drop of each elbow or bend	m	1.0	1.4	1.7

### Connection dimensions

Safety assembly connection	mm	22
Expansion valve end connection	mm	15
Expansion vessel connection, male, BSP		G 3/4 A
Tundish inlet connection	mm	22
Tundish outlet connection	mm	28

## 16.6 Heat-up diagrams

The heat-up time depends on the cylinder capacity, cold water inlet temperature and heating output.

Diagrams refer to 15 °C cold water inlet temperature:

### Temperature setting 50 °C

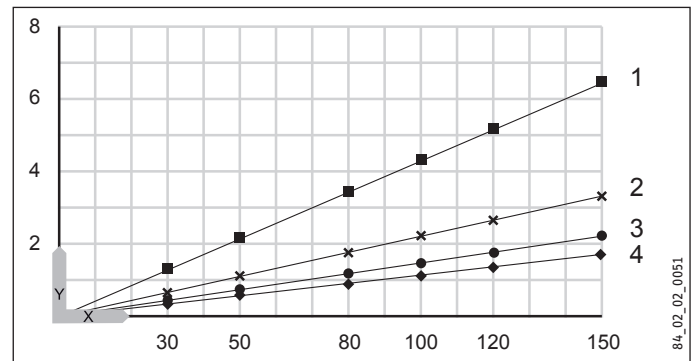

### Temperature setting 70 °C

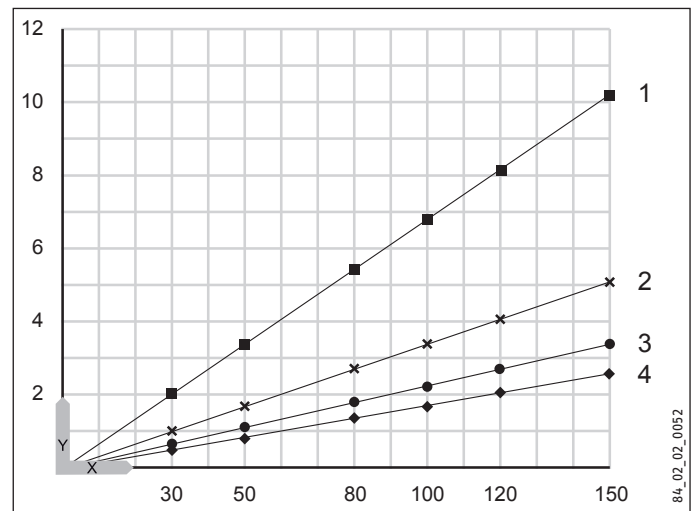

X Nominal capacity in l

Y Duration in h

1 1 kW

2 2 kW

3 3 kW

4 4 kW

## 16.7 Fault conditions

In the event of a fault, temperatures of up to 85 °C at 0.6 MPa can occur.

# INSTALLATION Specification

## 16.8 Details on energy consumption

Product datasheet: Conventional water heaters to regulation (EU) no. 812/2013 and 814/2013

		SHZ 30 S (GB) 232783	SHZ 50 S (GB) 232784	SHZ 100 S (GB) 232786	SHZ 150 S (GB) 232788
Manufacturer		STIEBEL ELTRON	STIEBEL ELTRON	STIEBEL ELTRON	STIEBEL ELTRON
Load profile		S	M	L	L
Energy efficiency category		B	C	C	C
Energy conversion efficiency	%	36	38	38	38
Daily power consumption	kWh	2.437	6.233	12.288	12.398
Annual power consumption	kWh	518	1349	2666	2685
Default temperature setting	°C	60	60	60	60
Sound power level	dB(A)	15	15	15	15

## 16.9 Data table

		SHZ 30 S (GB) 232783	SHZ 50 S (GB) 232784	SHZ 100 S (GB) 232786	SHZ 150 S (GB) 232788
<b>Hydraulic data</b>					
Nominal capacity	l	30	50	100	150
Amount of mixed water 40 °C (15 °C/60 °C)	l	58	97	198	290
<b>Electrical data</b>					
Connected load ~ 230 V	kW	1-4	1-4	1-4	1-4
Rated voltage	V	230	230	230	230
Phases		1/N/PE	1/N/PE	1/N/PE	1/N/PE
Frequency	Hz	50	50	50	50
Single circuit operating mode		X	X	X	X
Dual circuit operating mode		X	X	X	X
Manual rapid heat-up operating mode		X	X	X	X
<b>Application limits</b>					
Temperature setting range	°C	35-70	35-70	35-70	35-70
Max. permissible pressure	MPa	0.6	0.6	0.6	0.6
Test pressure	MPa	0.78	0.78	0.78	0.78
Max. Flow rate	l/min	18	18	18	18
Safety valve, nominal pressure	MPa	0.6	0.6	0.6	0.6
T&P valve, nominal pressure	MPa	0.7	0.7	0.7	0.7
T&P valve, temperature setting	°C	90	90	90	90
Pressure reducing valve	MPa	0.35	0.35	0.35	0.35
Volume, expansion vessel	l	8	8	8	8
Min./max. conductivity, drinking water	µS/cm	100-1500	100-1500	100-1500	100-1500
<b>Energy data</b>					
Standby energy consumption/24 h at 65 °C	kWh	0.46	0.54	0.86	1.1
<b>Versions</b>					
IP rating		IP24	IP24	IP24	IP24
Sealed unvented type		X	X	X	X
Colour		White	White	White	White
<b>Dimensions</b>					
Height	mm	846	816	1126	1521
Width	mm	410	510	510	510
Depth	mm	420	510	510	510
<b>Weights</b>					
Weight, dry	kg	23.5	28.4	39.9	53.3
Weight, full	kg	54	78	140	209

### **Guarantee**

The guarantee conditions of our German companies do not apply to appliances acquired outside of Germany. In countries where our subsidiaries sell our products a guarantee can only be issued by those subsidiaries. Such guarantee is only granted if the subsidiary has issued its own terms of guarantee. No other guarantee will be granted.

We shall not provide any guarantee for appliances acquired in countries where we have no subsidiary to sell our products. This will not affect warranties issued by any importers.

### **Environment and recycling**

We would ask you to help protect the environment. After use, dispose of the various materials in accordance with national regulations.